

# WHICH ASTM OTR TEST METHOD IS RIGHT FOR YOUR APPLICATION?

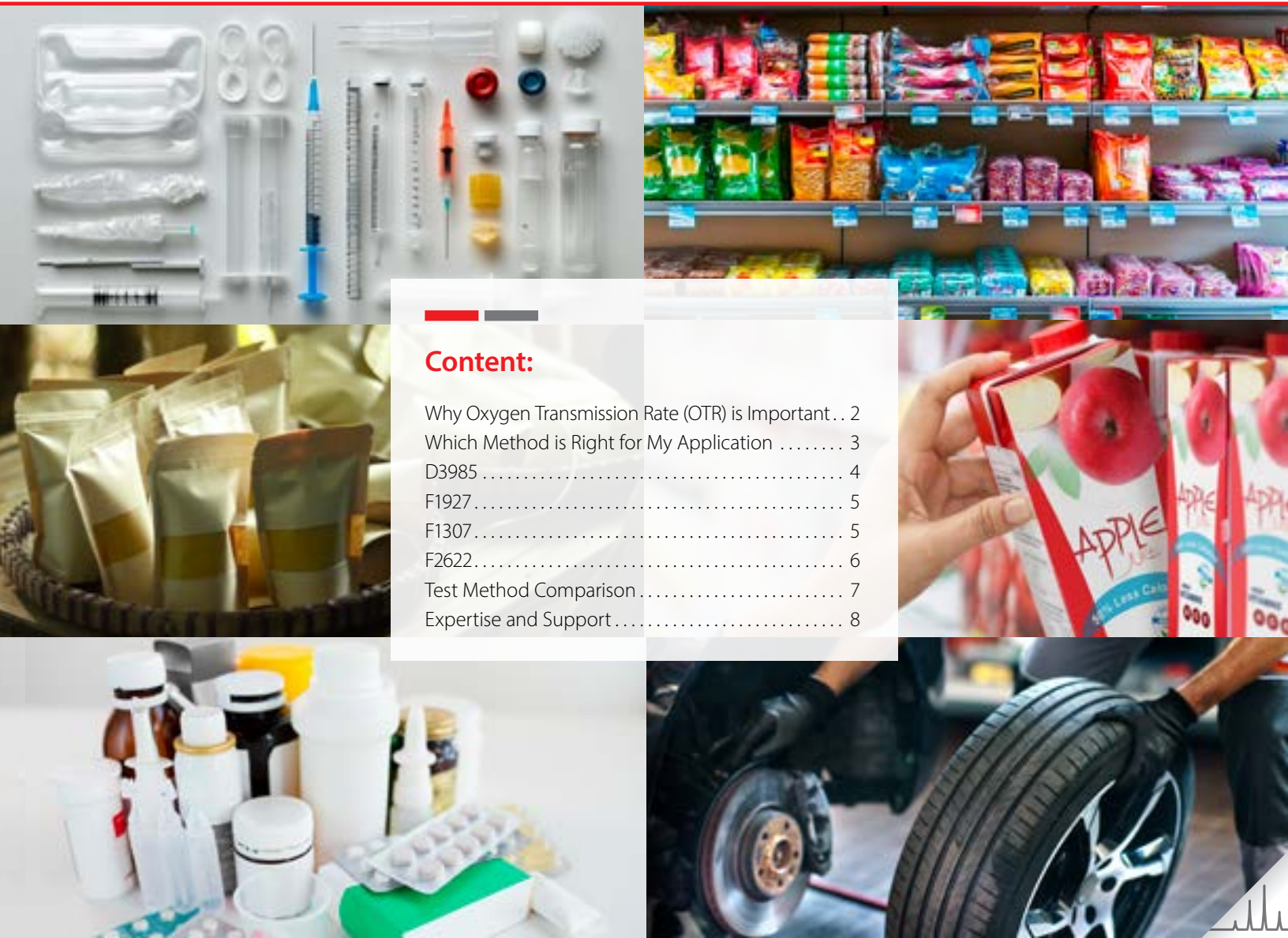

AMETEK MOCON

April 2026



## Content:

Why Oxygen Transmission Rate (OTR) is Important . .	2
Which Method is Right for My Application . . . . .	3
D3985 . . . . .	4
F1927 . . . . .	5
F1307 . . . . .	5
F2622 . . . . .	6
Test Method Comparison . . . . .	7
Expertise and Support . . . . .	8

## Abstract

Oxygen Transmission Rate (OTR) through materials plays a critical role across a wide range of industries and applications. Whether it's preserving the freshness of packaged food, protecting the integrity of blood products, maintaining proper tire pressure, or even enhancing the flavor of your coffee — how quickly oxygen passes through a material can significantly impact product quality, performance and safety.

## Introduction: Why is OTR Important?

OTR is a critical parameter in evaluating the barrier properties of packaging materials. It measures the amount of oxygen gas that permeates through a material over a given time and area. OTR testing is essential across various industries to ensure product quality, safety and longevity.



*Dried meats require high oxygen barriers to protect them for long shelf life*



*Medical packaging is crucial to maintain the sterility and efficacy*



*Electronics need to be protected from oxidation*

## Key Industry Considerations for OTR Testing

### Food Packaging

OTR testing is critical for maintaining product quality, safety and shelf life.

- Oxygen exposure leads to oxidation of fats and oils (causing rancidity and off-flavors) and supports microbial growth such as molds and yeasts
- Testing helps identify materials that best preserve freshness and extend shelf life—especially for snacks, coffee, meats and dairy products

### Healthcare and Pharmaceutical Packaging

Oxygen can degrade ingredients, reducing drug potency and stability.

- Packaging protects active pharmaceutical ingredients (APIs) from oxygen exposure
- OTR testing helps determine shelf life and efficacy and is often required in early FDA submissions to verify product reliability

### Medical Device Packaging

Barrier materials are critical to protect diagnostic devices, implants and surgical instruments.

- Barriers prevent oxygen-induced degradation and maintain sterility
- Testing validates barrier performance under real-world conditions

### Industrial Applications

Oxygen barriers are widely used in aerospace, automotive and chemical storage industries.

- These barriers prevent oxidation and corrosion of metal components, sensitive electronics and sensors
- Testing ensures the integrity of fuel systems, coatings and composite materials

## Conclusion:

OTR testing is a critical quality control measure that informs material selection, supports regulatory compliance, and ensures optimal product performance across food, healthcare, medical and industrial sectors.

# WHICH ASTM OTR TEST METHOD IS RIGHT FOR YOUR APPLICATION?

## Comparing ASTM Oxygen Transmission Rate (OTR) Test Methods

This white paper provides a comparative overview of four ASTM OTR test methods—**ASTM D3985, ASTM F1927, ASTM F1307 and ASTM F2622.**

### Application Scenarios: Real-World Use of ASTM OTR Methods

**ASTM D3985** — Ideal for testing **moderate to high-barrier materials.**

- Metallized polymer films in snack and food packaging — its precision helps ensure long shelf life and product freshness
- Encapsulation materials in electronics
- Foil pouches for medical devices
- Syringes and pharmaceutical vials

**ASTM F1927** — Designed for **multilayer film characterization**, especially with moisture-sensitive oxygen barriers such as EVOH and nylon.

- Frequently used in packaging coffee, vacuum-packed seafood and meat products
- Ensures barrier performance under varying humidity conditions

**ASTM F1307** — Suited for evaluating **formed components and complete packages.**

- Bottles, trays and blister cavities
- Full-package testing that incorporates closures and seals — this method is valuable for assessing the integrity of packaging systems as a whole

**ASTM F2622** — Optimized for **high-transmission materials.**

- Fresh produce and bakery items
- Household goods using compostable, paper-based barriers
- Development and validation of oxygen barrier coatings

### Conclusion

Each ASTM method offers unique advantages depending on the material type, packaging format and product sensitivity to oxygen. Selecting the appropriate OTR test method is essential for ensuring product quality, regulatory compliance, and performance across food, healthcare, medical and industrial sectors.

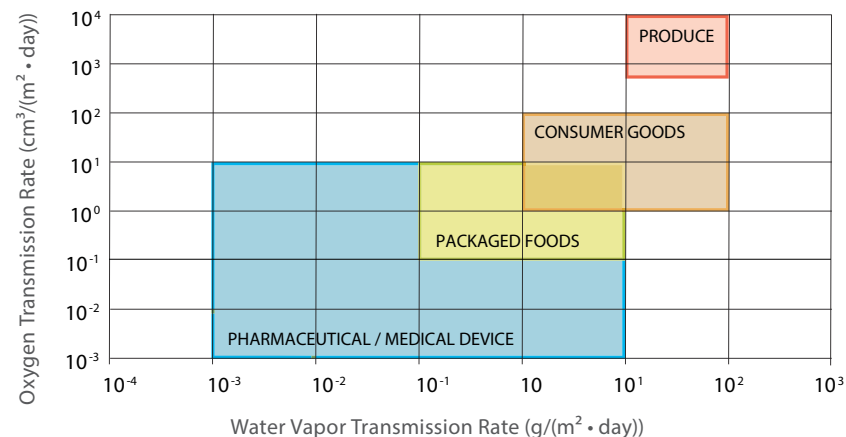

Protein powders need very high barriers



Many meats contain moisture when packaged



Cartons require testing of the seams, seals and closures



Produce and salad mixes require some gas transmission to avoid premature spoilage



ASTM D3985 is the most commonly used OTR method in laboratories around the world

## ASTM D3985 – Coulometric Sensor Method

ASTM D3985 is the industry-standard method for measuring OTR using a coulometric sensor. This method was pioneered by MOCON® and is highly regarded for its ease of use, precision and reliability, especially in applications requiring low OTR detection. Details of the method were qualified under an independent laboratory study (ILS). The test system utilizes a carrier gas mixture of nitrogen and hydrogen, which passes through a catalyst to remove residual oxygen in the carrier gas stream (this is critical for low-level OTR testing). The sample film is mounted within a diffusion cell, separating the oxygen-rich chamber from the carrier gas chamber.

The intrinsic coulometric sensor chemically converts all oxygen molecules to electrons that permeate through the film or sample with 95% – 98% efficiency. This absolute sensor approach does not require calibration, making this method ideal for quality control or regulatory compliance and is commonly used as a globally accepted reference method. The innate linear response of the sensor ensures accurate readings across a wide range of transmission rates (from as low as 0.0005 to 2000 cc/(m<sup>2</sup> · day)). Additionally, with gas detection levels below ppb level (1 ppm is equivalent to 2.8 cc (m<sup>2</sup> · day)), the ability for individual zero measurements to eliminate system bias is a critical element of the ASTM standard.

Note: High permeating materials can be tested by reducing the test area (masking) or using lower oxygen concentration (<100% O<sub>2</sub>) in the test gas to keep the instrument from over-ranging.

### Key Apparatus Elements:

- Trusted OTR reference method over a wide range of applications
- Coulometric sensor with 95%+ efficiency
- Carrier gas: N<sub>2</sub>/H<sub>2</sub> with catalyst
- Intrinsic linear sensor (measures 100% of carrier gas over a range of 7 magnitudes of OTR levels)
- Individual Zero circuit to measure the background for subtraction

### Applications:

- The method is best suited for moderate to ultra-high barrier films used in food packaging, pharmaceuticals and electronics
- Ideal for absolute transmission rate values below 1 cc/(m<sup>2</sup> · day)
- Its ability to deliver absolute transmission rate values without ongoing calibrations makes it a preferred choice for critical applications

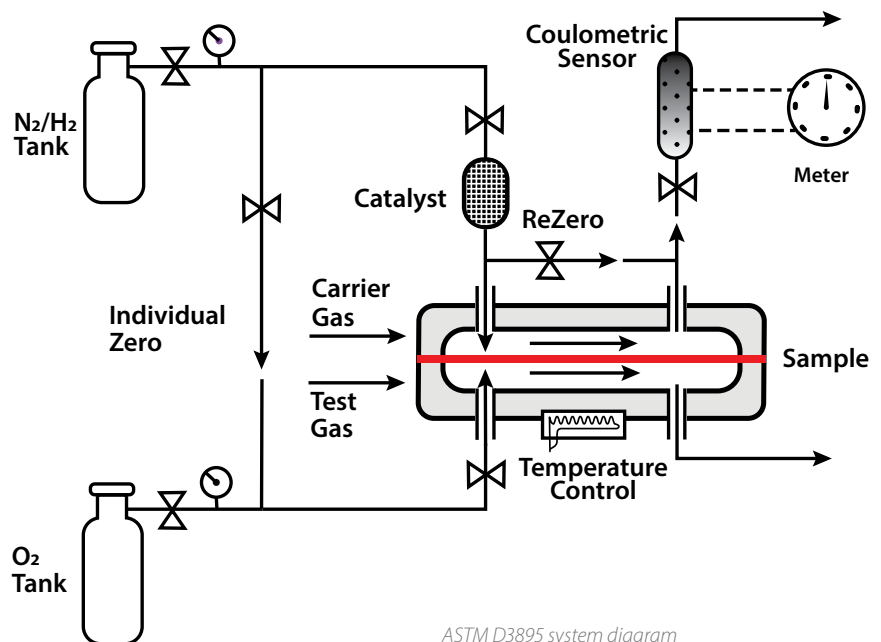

ASTM D3985 system diagram

## ASTM F1927 – Humidity-Enhanced Coulometric Testing

ASTM F1927 extends the capabilities of D3985 by incorporating humidity control into the test environment. This is crucial for materials like EVOH, nylon and coated paper, which are sensitive to moisture. The method uses the same coulometric sensor and carrier gas system but adds humidity to replicate real-life conditions.

### Key Apparatus Elements:

- Humidification of both test gas and carrier gas supply before the test chamber
- Intrinsic Coulometric sensor with high efficiency and linearity over 7 orders of magnitude

### Applications

- Packaging for coffee and meats, along with oxygen sensitive pharmaceutical and medical device products requiring long term stability
- The ability to test under ambient and “worse case” relative humidity conditions provides realistic data to gauge product performance

Learn more about [ASTM F1927](#)

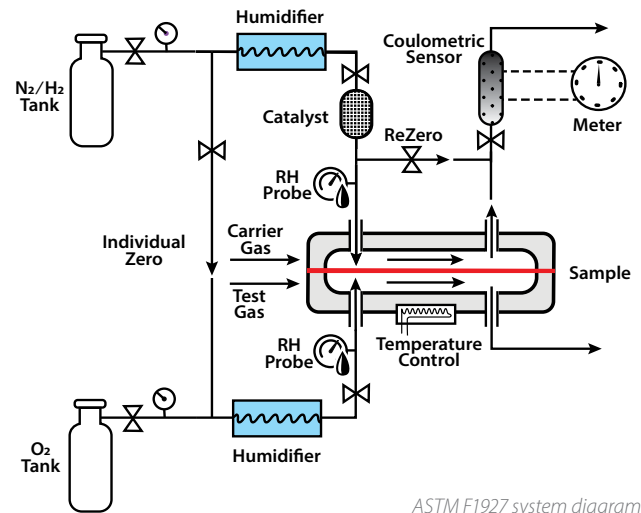

ASTM F1927 system diagram

Effects of Humidity on Oxygen Transmission Rate		
Polymer	0% RH	100% RH
ABS	0.06	0.06
HDPE	6.6	6.6
LDPE	28.8	28.8
Nylon 6	0.06	0.3
PVA	3.3	9.0
EVOH	0.0006	1.5
Coated paper	0.5	12.0

## ASTM F1307 Package and Closure Testing

ASTM F1307 is designed to test oxygen transmission through complete packages and closures. It builds on the D3985 method by adapting the apparatus to accommodate pouches, rigid containers and bottle/closure systems. The test gas is typically 20.9% or 100% oxygen, and the method can be performed under dry or humid conditions.

### Key Apparatus Elements:

- Adaptors for three-dimensional sample mounting
- High flow-rate purge capability to reduce testing time

### Applications:

- Verify and validate package OTR performance to theoretical calculations
- Compare different package seams, seals and closures
- Understand process parameters in the package production

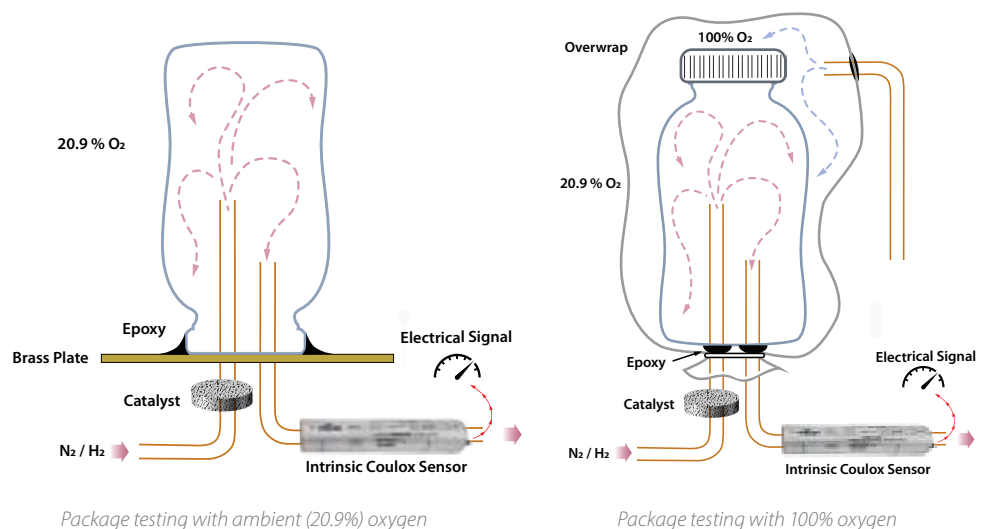

Learn more about [ASTM F1307](#)



ASTM F2622 is the preferred method for higher-transmission barrier testing

## ASTM F2622 – Alternative Sensor Technologies

ASTM F2622 provides flexibility by allowing various sensor technologies such as electrochemical and zirconia oxygen sensors. This method is suitable for higher OTR “permeating” materials (such as produce packaging) and is commonly used in product development of coatings for compostable / paper substrates and packages. Unlike the intrinsic coulometric sensor in D3985, which reacts with all of the oxygen gas transmitted, these sensors sample a fraction of the transmitting oxygen and measure the concentration of oxygen in the carrier gas stream. These technologies require calibration and are influenced by factors such as flow rate, pressure and temperature. As such, instruments conforming to this method need to be verified more often, due to potential drift of the calibration.

The test setup includes a diffusion cell, sensor chamber and calibration system. While it offers broader applicability for high oxygen transmitters, it may not be as accurate or repeatable for low OTR measurements, where quantifying only a fraction of the low oxygen concentration becomes a challenge. Despite these limitations, ASTM F2622 is valuable for a wide range of packaging and consumer goods, and other moderate to low barrier applications.

### Key Differences from D3985:

- Requires calibration and frequent verification
- Not all transmitting O<sub>2</sub> gets quantified
- Accuracy depends on flow, pressure and sensor temperature calibrations (more calibrated components lead to greater stacked error with the measurement)
- Less accurate below 1 cc/(m<sup>2</sup> · day)
- Ability to test both dry and with humidity (like F1927)

### Key Apparatus Elements:

- Alternative sensor options with high OTR range capability
- Carrier gas: ultra high purity N<sub>2</sub> (99.997%) with O<sub>2</sub> absorber
- Flow meter to quantify gas measurement

### Applications:

- Recommended for higher transmission rate values above 100 cc/(m<sup>2</sup> · day)
- Ideal for testing unknown samples during paper coating development
- Companies seeking a versatile testing method for a wide range of materials often choose ASTM F2622 for its adaptability

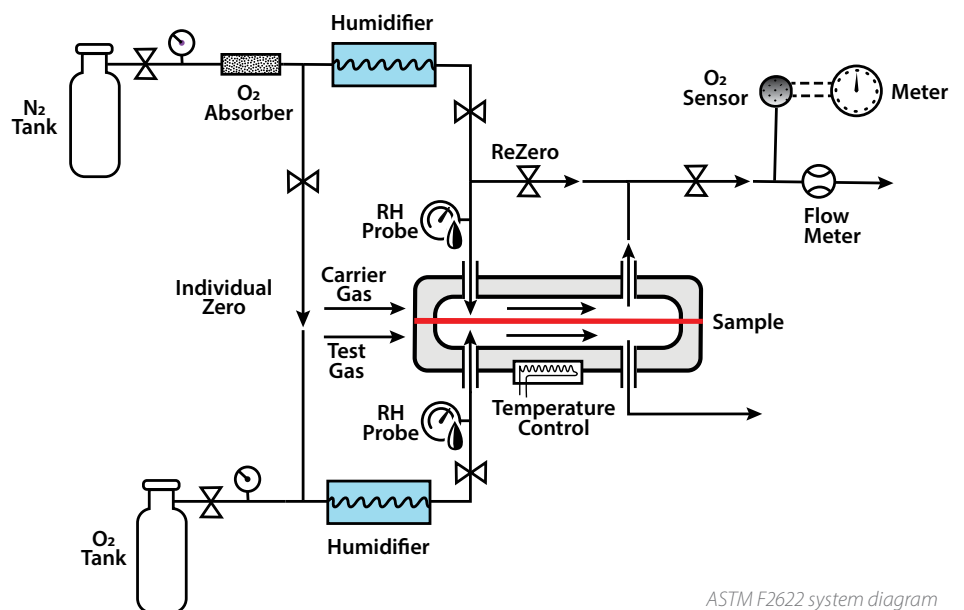

ASTM F2622 system diagram

Learn more about [ASTM F2622](#)

## Comparison Table

Selecting the right ASTM OTR test method is critical for ensuring product quality, regulatory compliance and customer satisfaction. Each method offers unique advantages depending on the application and material properties of the sample.

Method	ASTM D3985	ASTM F1927	ASTM F1307	ASTM F2622
Sensor type	Coulometric	Coulometric + humidity	Coulometric	Various
Measurement level	High to ultra-low Range: 1000 – 0.00001 cc/m <sup>2</sup> • day	High to ultra-low Range: 1000 – 0.00001 cc/m <sup>2</sup> • day	High to ultra-low Range: 1 – 0.000025 cc/pkg • day	Ultra-high to moderate Range: 500,000 – 0.05 cc/m <sup>2</sup> • day
Sensor calibration	Not required	Not required	Not required	Required
Best use case	Moderate to high-barrier films	Moisture-sensitive multilayer films	Full package and closure systems	General-purpose OTR testing
MOCON instruments	OX-TRAN 2/22, 2/28	OX-TRAN 2/22, 2/28	OX-TRAN 2/22, 2/28, 2/48, 2/40	OX-TRAN 2/12



OX-TRAN 2/22



OX-TRAN 2/28



OX-TRAN 2/48



OX-TRAN 2/40



OX-TRAN 2/12

## OTR Test Methods: pros & cons to guide your selection

Test Method	Pros	Cons
ASTM D3985	<ul style="list-style-type: none"> <li>- Industry standard for many applications</li> <li>- Absolute sensor for high to ultra-low level detection</li> <li>- High accuracy and repeatability qualify this to be commonly used as a reference method.</li> </ul>	<ul style="list-style-type: none"> <li>- Requires masking or low %O<sub>2</sub> gasses when testing very high oxygen transmitters</li> </ul>
ASTM F1927*	<ul style="list-style-type: none"> <li>- Testing materials under humidified conditions (real world scenarios)</li> </ul>	<ul style="list-style-type: none"> <li>- Increased calibration for RH probes</li> </ul>
ASTM F1307*	<ul style="list-style-type: none"> <li>- Testing three-dimensional samples or packages to understand seams, seals and wall thickness</li> </ul>	<ul style="list-style-type: none"> <li>- Need to verify integrity of sample mounting to get accurate results</li> </ul>
ASTM F2622	<ul style="list-style-type: none"> <li>- Great for high transmitters and moderate barrier materials</li> <li>- Useful for screening unknown samples to prevent overrange of sensor</li> <li>- Included humidified testing conditions</li> </ul>	<ul style="list-style-type: none"> <li>- Limited capability for high barrier materials</li> <li>- Requires frequent calibration and verification of sensor and flow meter</li> </ul>

\* Similar pros/cons to D3985

---

## We go beyond industry-leading instruments and accessories

Since 1966, we have set the industry standard in precision gas permeation testing and package testing instrumentation. Our dedicated team and innovative products offer the best value with an extensive range of solutions. Trusted by companies worldwide, we deliver the most accurate and repeatable results to ensure and enhance the quality and integrity of product packaging.



---

The world's largest permeation testing lab



---

Comprehensive advanced permeation testing training

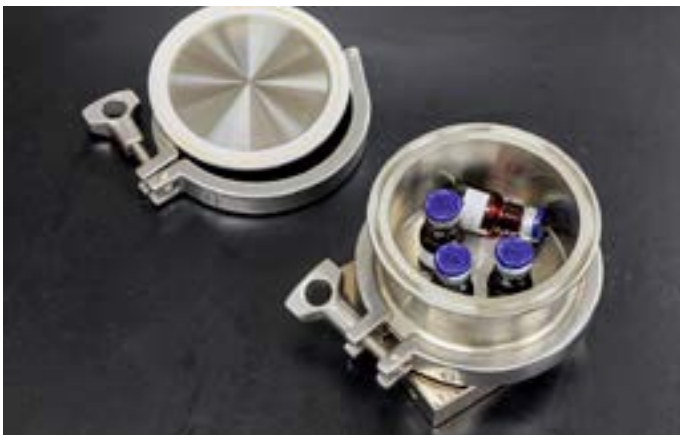

---

Custom application development and lab testing services for industries like healthcare, packaging and food & beverage



---

Since 1966, over 70 patents have been awarded for instruments developed by AMETEK MOCON